

# ***BS-pilotDRY***<sup>®</sup>

## Pilot conical dryer/mixer



Applications & Processes



## **BOLZ-SUMMIX Pilot conical dryer/mixer the small “work horse” with wide ranges of applications**

**Universal conical pilot dryer and mixer. For development and refinement of new and existing products, pilot scale testing plays an indispensable role in the industry.**

In response to increased customer expectation BOLZ-SUMMIX has worked for many years with their partners in the pharmaceutical and fine chemical industries, to continuously develop its range of mobile pilot mixers and vacuum dryers. They are used extensively within these fields and have proved to be very successful, however because of restrictive access, several clients were in a dilemma and it became a major priority for us to solve this problem. This involved reducing the height of the unit during transport between working areas and improving their mobility. Our mixer with its new compact support structure (with very low transport position) answers all these problems, allowing for the unit to be moved easily through doorways, corridors and lifts.

We have applied our comprehensive know-how in the design of conical screw mixer/dryers with the above to improve the flexibility of our pilot equipment to our customers advantage.

These user friendly, self contained systems permit the production of multistage processes on a technical pilot scale, i.e. drying under vacuum conditions, mixing, wetting, coating, granulating (de-dusting) and a host of other techniques, under a controlled dust free environment, all with a high degree of precision, gentle mixing action and low energy inputs. They represent a true to scale simulation of the physical conditions and results obtained in large scale production facilities, helping to prove and optimise existing processes or develop new ones.



### **Full range of equipment specification and options**

A wide range of alternative specifications are available, for instance, infinitely variable speed drive, a closed circuit heating system, dust filter, vacuum and condenser for recovery of vapours. Injection devices, C.I.P. systems, samplers – allowing samples to be taken whilst vessel is under vacuum, heated mixing screw, electrical control panels to meet a variety operational conditions.

The pilot systems are manufactured to conform to a range of national standards and regulations, including PED, ASME, Stoomwezen, GB 150. The various options incorporate the relevant standards for dust explosion and flame proofing. The system is completed by a tailor-made, easy to use control system which fulfills the latest ATEX requirements in respect of ATEX zones 1, 21 and 2, 22 and has proven as easy to handle and reliable during many trials.

Our mobile pilot dryer/mixers are totally independent upon the physical constraints of the area within which they are expected to operate. To optimise the philosophy of “plug in and go”, they can now be provided with a unique system for reducing the overall height, whilst transporting the unit through doors, corridors and lifts e.g. our 30 liters working capacity unit has an overall height of 1850 mm and width of 1400 mm in the transporting mode. Once in position, the entire unit can be raised to operating height. In addition to this the cone can be lowered from the fixed top cover (after loosening clamps) to enable the vessel to be checked for cleanliness after a C.I.P. cycle.

One highlight is the redesigned, optionally available hybrid stirrer, that opens the possibility for the lab dryer either to work as conical screw dryer, or to be used also as central shaft dryer. Innovative technical developments facilitate this unique variability of the new **BS-miniDRY®**. This allows testing of general suitability and direct comparison of the lab results of one agitator's performance with another.

There are three sizes, 10, 30 and 50 liters nominal working capacity, which are ideal for product development, long experimental trials, pre-production batches for possibly quality assurance purposes or market research, pilot scale and small batch production, including small pharmaceutical operations, polymer research and many other tasks in the pharmaceutical and fine chemical fields.

The closed circuit drying systems are designed to meet the increasingly strict environmental protection requirements and are constantly being reviewed to keep ahead of them. They are designed as pressure vessels and prevent the escape of toxic or dangerous substances into the environment. The heating system supplies the hot water jackets on the cone, top cover and filter housing and the vacuum/condenser system recovers the vapours. In other words, the entire process takes place within a totally enclosed and controlled environment.



#### Standard specifications:

Material	SS 316L or Alloy C22
Working volume	Type ML001: 10 bis 50 liters
Working pressure	-1,0 to 3.0 barg
Working temp.	-20°C to 120°C
Heating/Cooling	Water/thermal oil at 0 to 6 barg
Surfaces	inside Ra <0,8 µm

#### Basics:

- Heating/Cooling jacket
- Insulation jacket
- Dust filter
- Two drives with variable speeds
- Manual ball discharge valve
- Pressure and temperature sensors
- Sampler
- High adjustable support frame

#### Options:

- **Hybrid stirrer with central shaft mixer**
- Vacuum system with solvent recovery
- Heating/Cooling system
- SPS Control with Lab software
- Operation via PC or Laptop
- Free programmable process control
- ATEX Conformity
- Please ask for additional, special equipments

#### Summary of dimensions of BOLZ pilot conical dryer/mixer

Model	Effective capacity in liters	A	B	C	D	E	F	G	H	I	J	K	L
ML 001	15	2230	1985	1785	1455	300	625	1075	740	1170	1250	260	1883
ML 003	30	2595	2350	2150	1800	500	783	1345	900	1343	1480	260	2073
ML 005	50	2595	2450	2250	1900	500	783	1375	1050	1493	1630	260	2223

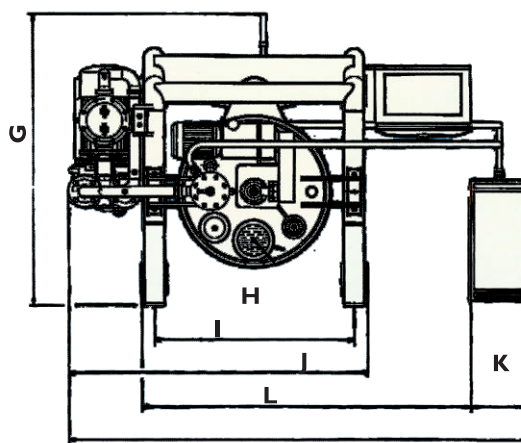
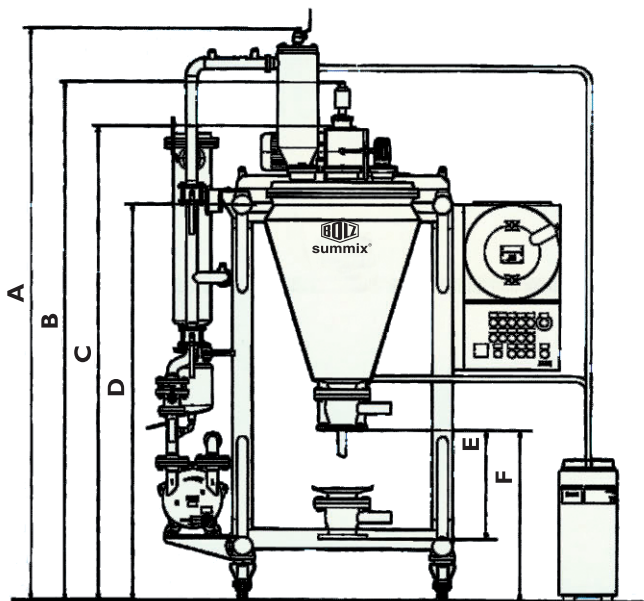

# BS-miniDRY® lab dryers and mixers for research, development and for smallest product volumes

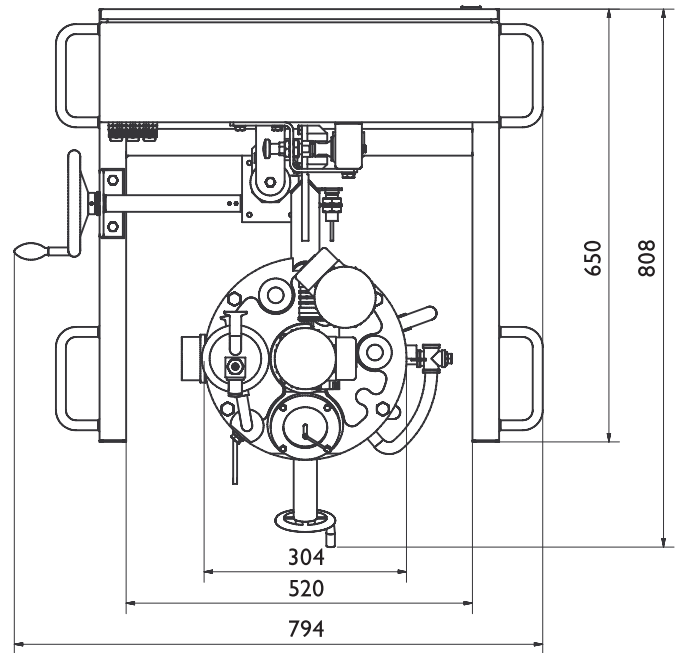
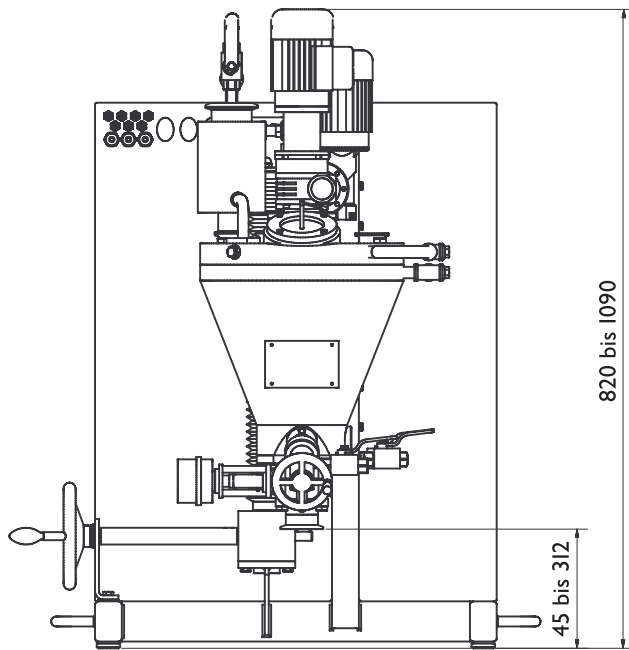

The new **BS-miniDRY®** is the ideal and logical development of the already very successful pilot dryers of the ML type, in the sizes 10 to 50 liters filling volume. Especially for Scale-Up of production machines, or for small volumes these apparatus sizes are suitable. A great number of materials and tailor-made designs are available also here.

**Upshot:** Entirely new work and simulation possibilities turn out through the use of the new lab dryer during the development of the new products in the laboratory standard. Processes with small product amounts, below the amounts for kilo lab installations, can be simulated now to an early time of the development in order to gain already now important findings for the later, practical conversion in the production standard, as well as their optimization.

For more information, please contact us.

**BOLZ**  
**Process Technology GmbH**  
 Sigmanner Weg 2  
 88239 Wangen  
 GERMANY  
 Phone +49 7522 9162-0  
 Fax +49 7522 9162-105  
 E-mail [info@bolz-pt.de](mailto:info@bolz-pt.de)  
 Internet [www.heinkel.com](http://www.heinkel.com)